

ergoselect 600 – Technical Specifications

Dimensions

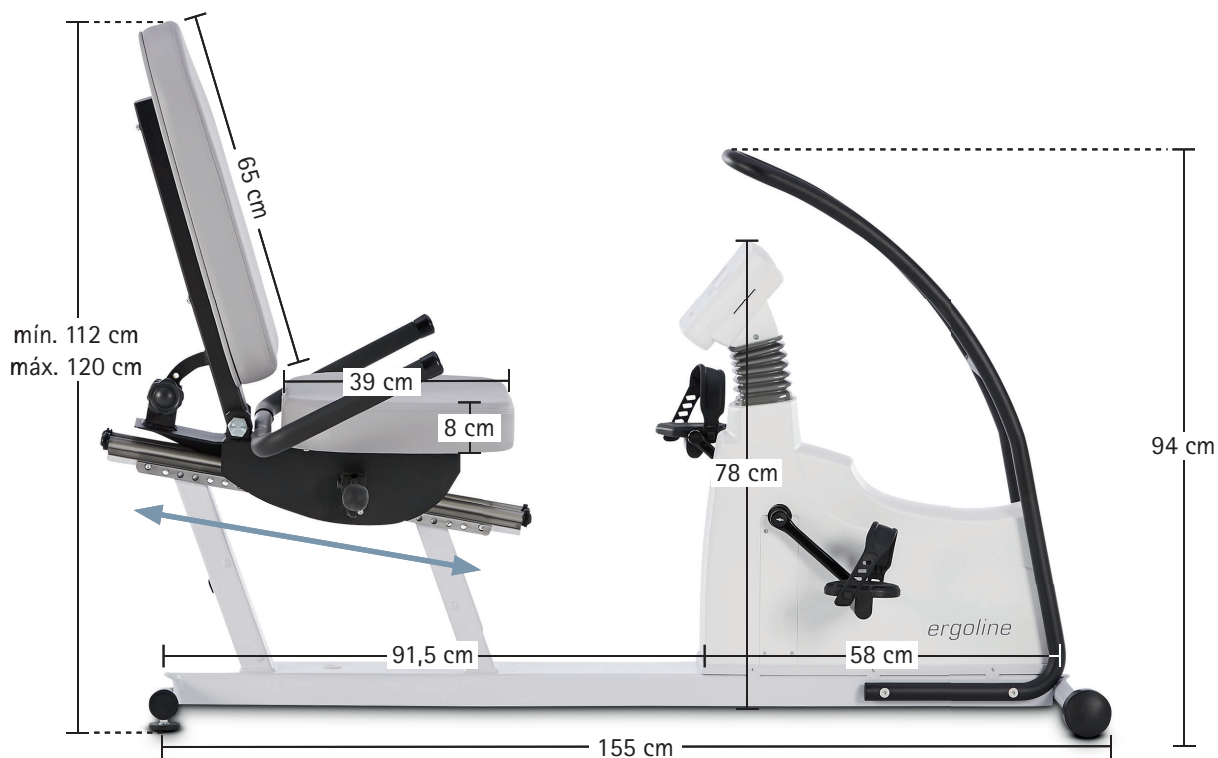

ergoselect 600 – Technical Specifications

Recumbent ergometer		ergoselect 600
Brake system	computer-controlled eddy current brake	
Load	6–999 watts, speed-independent	
Accuracy	to DIN VDE 0750-238	
Speed range	30–130 rpm	
Horizontal seat adjustment	for body height from 150 cm to 210 cm	
Patient weight (max.)	300 kg	
Width of seat	54 cm	
Control terminal		
Display/patient display	load, speed (rpm), time, blood pressure, heart rate (LCD)	
Graphic display (load or pulse curve)	○	
Keyboard	membrane keyboard	
Exercise test protocols		
User programmable	10	
Predefined incremental protocols (WHO, Hollmann, etc.)	5	
Manual load control	●	
Training protocols		
Various training protocols	○	
Preprogrammed performance tests	○	
Expansion options		
Automatic blood pressure measurement	○	
SpO2 measurement	○	
ECG amplifier (ERS rehabilitation system)	○	
Interfaces		
Digital (RS-232 USB)/analog/remote start	● / ○ / ○	
ERS rehabilitation system communication port	○	
Dimensions and weight		
Ergometer	Ergometer with packaging	
Length: 165 cm	Length: 209 cm	
Width: 75 cm	Width: 80 cm	
Height: 108 cm	Height: 157 cm	
Weight: 86 kg	Weight: approx. 100 kg	
Miscellaneous		
Power supply	100–240 V / 50–60 Hz / 100 VA max.	

● Standard ○ Option